

# Fitting Instructions

## Revo B9 2.0T Intercooler

Fitting Difficulty



### Contents

Description	Qty
Revo B9 2.0T Intercooler	1
Revo B9 2.0T Outlet Upper Bracket	1
Revo B9 2.0T Inlet Upper Bracket	1
Revo B9 2.0T Inlet Lower Bracket	1
Revo B9 2.0T Outlet Lower Bracket	1
M6 x 1 x 14mm Button Head Bolt	4
M8 Flat Washer	4
M8 x 1.25 x 14mm Button Head Bolt	4

### Recommended Tools

Tools	Size
Sockets	7, 8, 10mm
Ratchet	
Ratchet Extension	
Torx Bits	T25, T30
Long Nose Pliers	
Straight Screwdriver	medium



Before starting, please ensure that the battery is disconnected and the engine is cool. Engine temperatures can remain high for a substantial amount of time after use.

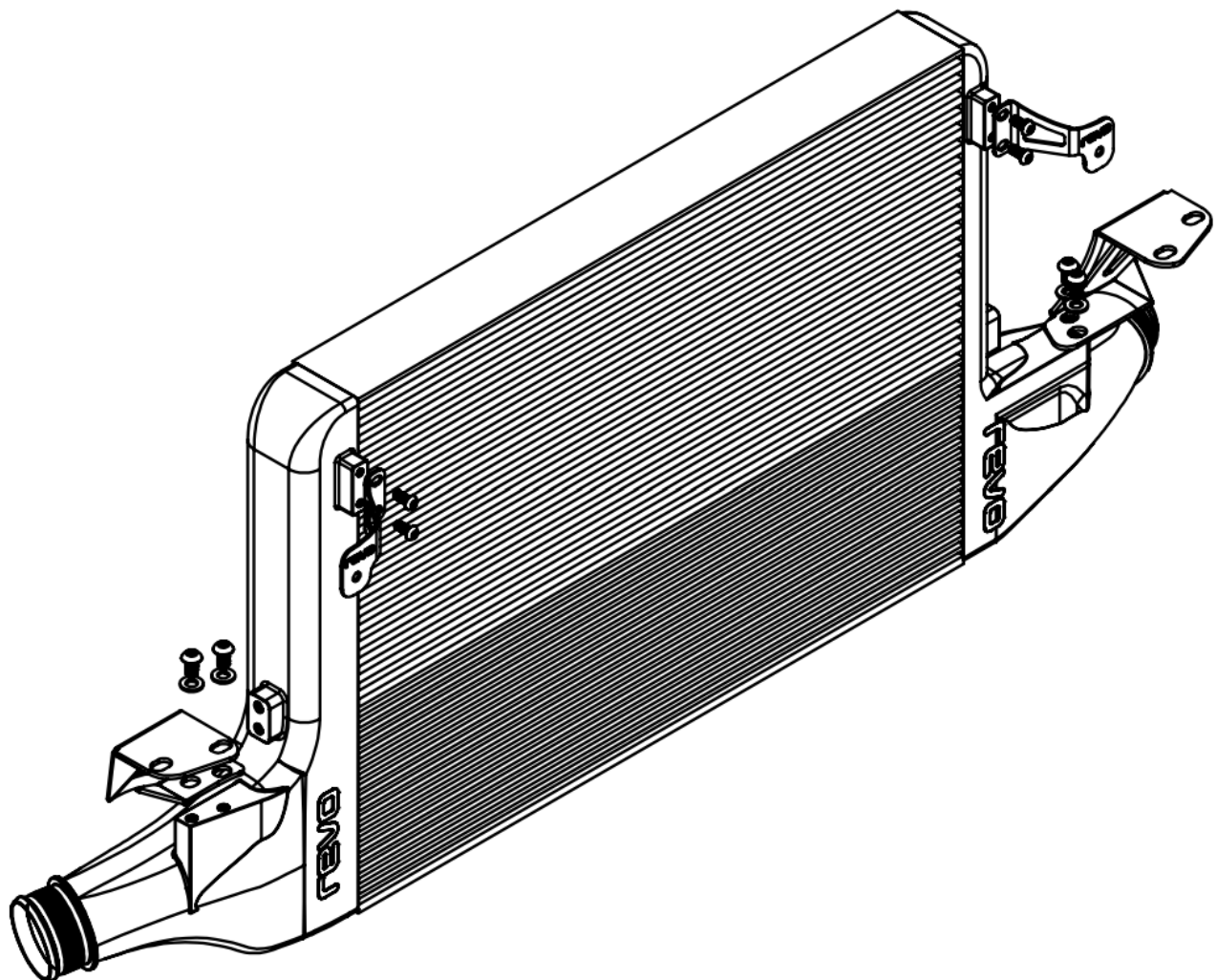

# Fitting Instructions

## Revo B9 2.0T Intercooler

Fitting Difficulty



Installation was performed on a UK-spec. B9 A4. Installation on other vehicles will be similar but may not be exact

- 1 Put the vehicle on a lift and raise in the air, then remove both front wheels. Remove (7) T25 bolts from the wheel arch liner as well as the (2) 10mm plastic nuts. Peel back wheel arch liner to give access behind.

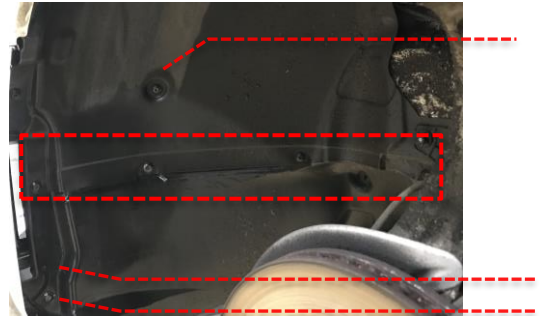

- 2 Remove the (1) plastic push-fit trim clip and the (1) T30 bolt that holds the bumper to the wing. Repeat steps 1 and 2 on opposite side of vehicle.

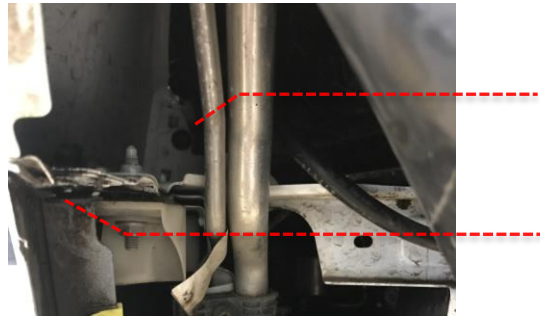

- 3 Remove (5) T30 and (2) T25 bolts that secure front bumper to main undertray.

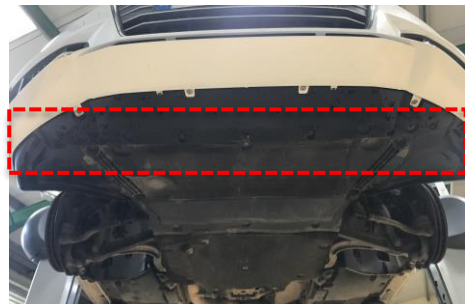

- 4 Lower vehicle and release bonnet. Remove bonnet release handle from the slam panel by pressing in the release catch at the 12 o'clock position.  
Note – do not close bonnet without refitting the release handle.



# Fitting Instructions

## Revo B9 2.0T Intercooler

Fitting Difficulty



- Remove the slam panel by unclipping along the front edge and then sliding it out from under the front air scoop.



- Remove (4) T30 bolts from the top of the bumper.

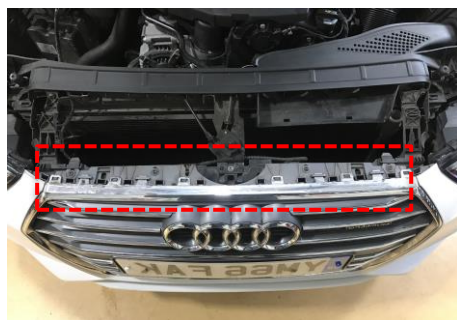

- Carefully pull the bumper free from the corner at each side.



- Whilst standing in front of the vehicle, carefully pull the bumper forwards to release it.



# Fitting Instructions

## Revo B9 2.0T Intercooler

Fitting Difficulty



- 9 Before the bumper can be removed fully, disconnect the front parking sensor located on the left-hand side of the bumper. Once disconnected, carefully place the bumper out of the work area.



- 10 Remove the multiplug from the sensors at each end of the crash bar foam padding. Pull the red clip out and then squeeze the multiplug to release.



- 11 Remove the crash bar foam padding and place out of the work area.



- 12 Remove the (2) 13mm bolts and (1) T30 bolt from each side of the crash bar and remove crash bar from the vehicle.



# Fitting Instructions

## Revo B9 2.0T Intercooler

Fitting Difficulty



- 13 Before fully removing the crash bar, disconnect the ambient air temperature sensor from the crash bar and then place it out of the work area.



- 14 Using a 7mm socket, loosen the hose clip on the discharge pipe and remove the pipe from the stock intercooler. Repeat for the throttle pipe on the opposite side.



- 15 Using a pair of long nose pliers, release the clips at the top of the stock intercooler, one on each side.

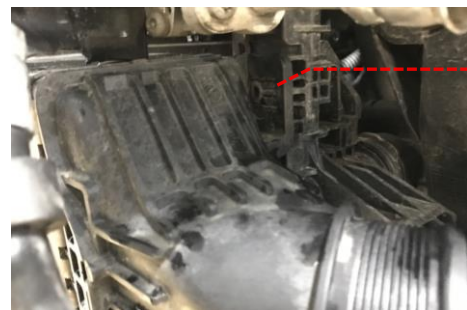

- 16 Roll the stock intercooler towards you to remove it from the bottom clips and lift the unit out.



# Fitting Instructions

## Revo B9 2.0T Intercooler

Fitting Difficulty



- 17 Remove the (1) 8mm bolt from the plastic bottom radiator mount, pull the mount towards you and twist it outwards. Repeat for opposite side.

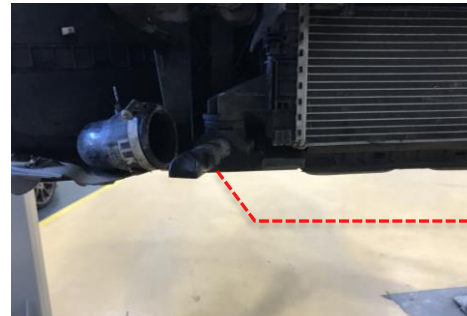

- 18 Position the new Revo intercooler in front of the radiator and use a gearbox stand/trolley jack and a piece of wood to support it. Straighten the bottom radiator mounts and refit the 8mm bolts.

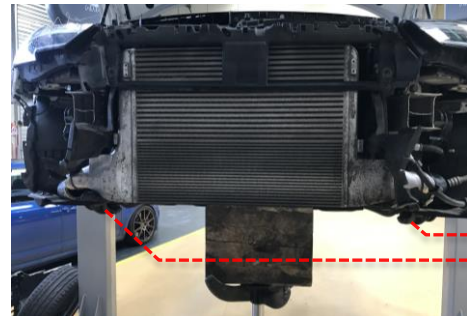

- 19 Loosely refit the crash bar but do not bolt it back in place.



- 20 Fit the (2) new Revo smaller intercooler brackets to the top of the Revo intercooler using the (4) 10mm bolts provided and then refit the (2) T30 bolts that go through the Revo bracket, crash bar and top radiator mount. Do not tighten yet.

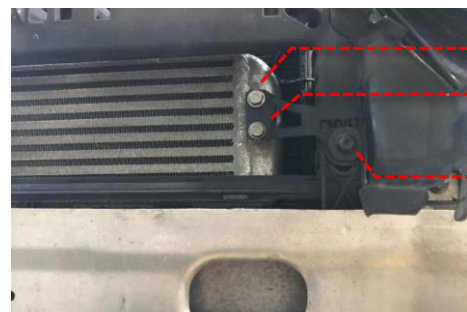

# Fitting Instructions

## Revo B9 2.0T Intercooler

Fitting Difficulty



- 21 Fit the new Revo lower intercooler brackets to the Revo intercooler using the (4) 13mm bolts and (8) washers provided. All washers to be placed on top of the bracket. Do not tighten yet.

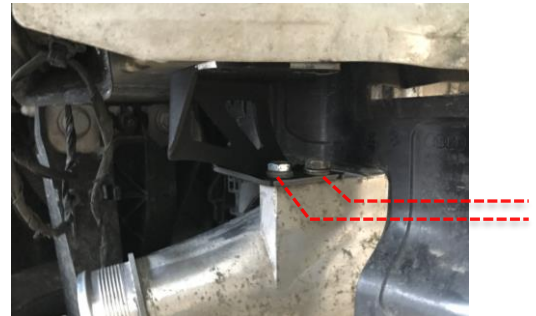

- 22 Refit the (4) 13mm crash bar bolts, which now also go through the Revo lower intercooler brackets. Do not tighten yet. Remove the gearbox stand/trolley jack and square up the Revo intercooler.

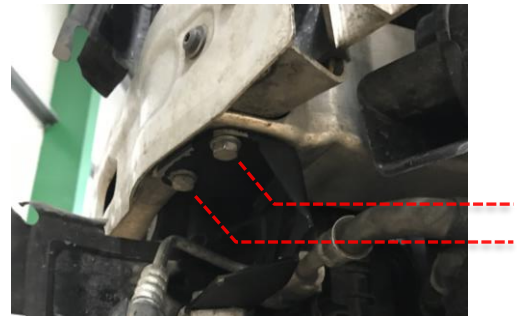

- 23 Tighten the (4) 13mm bolts that hold the lower brackets to the Revo intercooler, then tighten the (4) 13mm crash bar bolts, followed by the (4) 10mm bolts holding the top brackets to the Revo intercooler and finally the (2) T30 bolts holding the top brackets to the top radiator mounts.

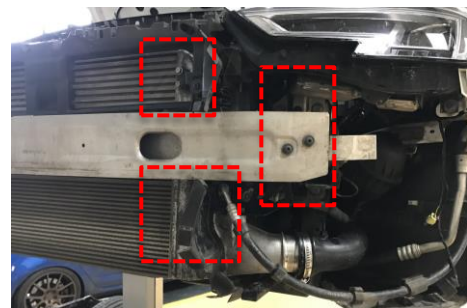

- 24 Refit all OE parts back to vehicle. Reinstallation is the reverse of removal. Follow any factory torque specification during reinstallation of OE parts. Check all sensors are reconnected. Also check bonnet release handle is refitted. Test drive the vehicle to ensure no leaks/part interference during operation. Your installation is now complete!

# Fitting Instructions

Revo B9 2.0T Intercooler

Fitting Difficulty

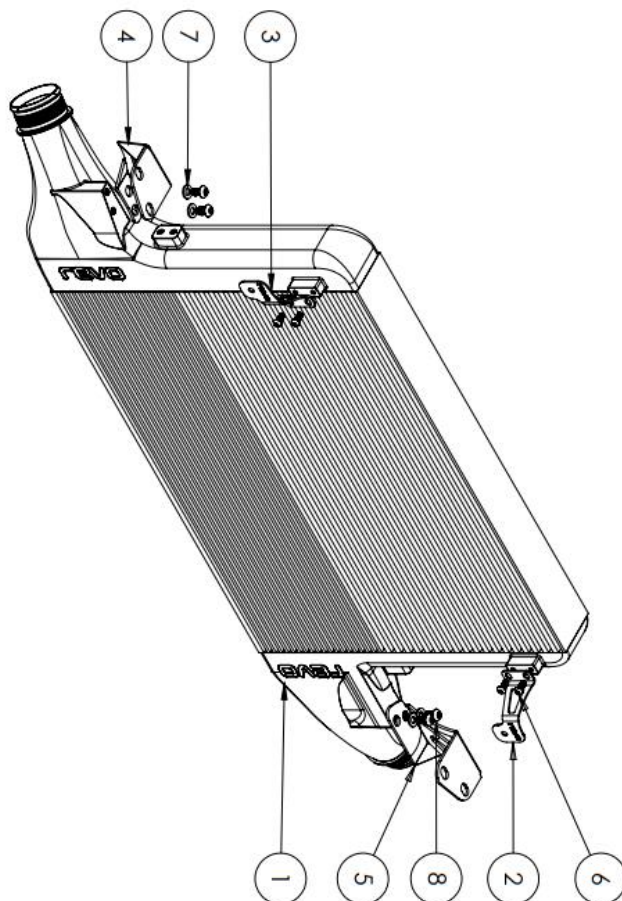

ITEM NO.	DESCRIPTION	QTY.
1	INTERCOOLER	1
2	UPPER OUTLET BRACKET	1
3	UPPER INLET BRACKET	1
4	LOWER INLET BRACKET	1
5	LOWER OUTLET BRACKET	1
6	M6 x 14mm x 14mm BHSCS STAINLESS	4
7	M8 WASHER STAINLESS STEEL	4
8	M8 x 1.25mm x 14mm BHSCS STAINLESS	4